

APPENDIX B. WIRING DIAGRAM - REMOTE CONTROL UNIT

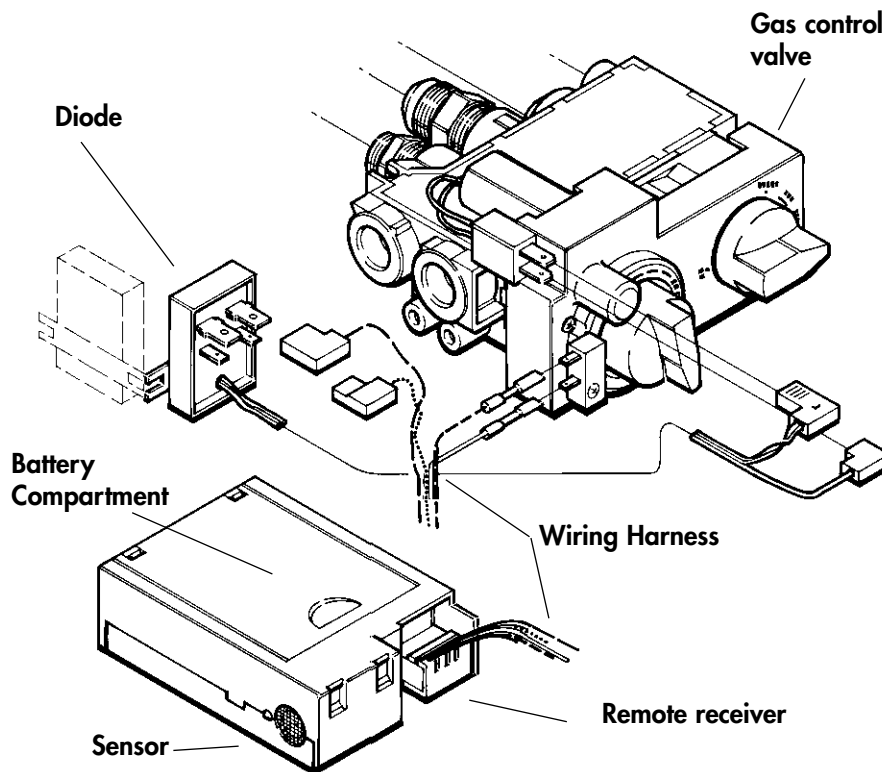

INSTALLATION INSTRUCTIONS FOR OPTIONAL REMOTE CONTROL RECEIVER

Your Cottage Franklin Gas Stove comes with a convenient HI-LO/ON-OFF switch as standard equipment. If you choose the optional remote control unit, installation is as easy as connecting the remote receiver and installing batteries in the transmitter and receiver.

Note: Removal of front casting will make installation easier.

Connecting the Remote Receiver:

The remote control unit consists of two components: A) the remote transmitter (requires one 9V battery); B) the remote receiver (required four AA batteries). Connection to the stove is made with a wiring harness also included.

- 1) Remove the cover plate. To access the control valve and diode the metal plate covering the control valve must be removed. Remove the two bolts on either side of the gas control knobs. Remove the plate and set aside. Consider where you would like to place your receiver. You will need to disconnect the large plug from the receiver. Pass it through the front of the stove, under it, and out to where the receiver will be placed.
- 2) Connect the loose end of the wiring harness to the diode (located to the left of the control valve) and the control valve.

The diode is mounted to a cast iron support to the left of the control valve. On the upper half of the diode are two male connectors. The left connector is larger and corresponds to the larger right angle female connector on the wiring harness. firmly attach both right angle connectors from the wiring

harness to the diode.

The two smaller female connectors on the wiring harness correspond to the two male connectors located on the left side of the control valve next to the left flame adjustment knob. Firmly attach the connectors on the wiring harness to the control valve. It makes no difference which is on top.

- 3) Connect the wiring harness to the receiver. The wiring harness used to connect the receiver has a large plastic plug on one end, and four smaller connectors at the other. With the sensor opening facing toward you at the right end of the receiver, slide the large plastic plug (wire side pointing up) firmly over the green tab on the right side of the receiver. Note: Plug will fit securely in only one position.
- 4) The battery pack for the HI-LO/ ON-OFF switch may be eliminated by connecting the switch to the remote receiver. The connection can be made with the conversion cable attached to the remote receiver. Simply detach the switch lead from its battery pack and connect it to the conversion cable on the remote receiver (see illustration 18.3).
- 5) Install required batteries after all wire connections have been made. The 9V battery for the transmitter is placed under the sliding cover on the back. There is also a battery compartment under the sliding cover on the receiver for the four AA batteries. Alkaline batteries are recommended.
- 6) Test your remote. The green LED on the receiver should light when a signal is received from the transmitter. Try pressing the large flame adjustment buttons on the transmitter. The left flame adjustment knob on the control valve should turn up or down as the buttons are pressed.

If the LED does not light or the flame adjustment knob does not turn when buttons are pressed check all connections and/or battery strength. The receiver sensor opening must be able to receive sound waves, be sure it is not obstructed.

- 7) Replace the control valve cover plate and front casting.

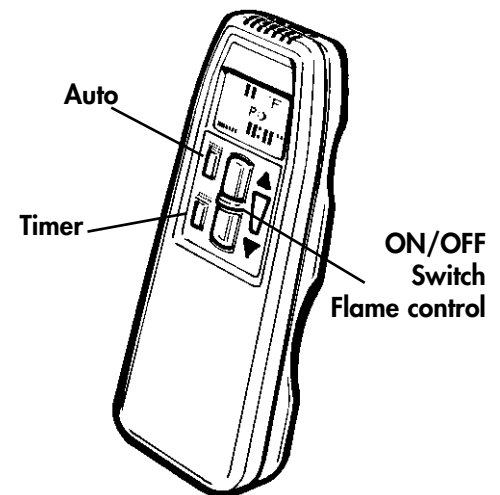

Illustration 18.2 Use the large buttons to turn the main burner ON or OFF and control flame height.

Illustration 18.3
Use the conversion cable to eliminate the second battery pack.

